



# DeckHardware

Marine Solutions Australasia

## PROVEN TOUGH



## MARINE GRADE COMPOSITE PLUMBING!



Chosen by Top Manufacturers



# FORESPAR<sup>®</sup> MARELON<sup>®</sup>

Corrosion Free • Unique Cost Saving Versatility • Extremely Strong

# **FORESPAR<sup>®</sup>**

---

# **MARELON<sup>®</sup>**

- Forespar<sup>®</sup> has been manufacturing marine hardware for over 40 years.
- Marelon<sup>®</sup> marine grade composite plumbing is used world-wide by the top names in boat building.
- It has been in use in thousands of boats for over 35 years.
- Marelon<sup>®</sup> valves can be monitored and/or operated remotely using the Forespar<sup>®</sup> ROV technology.
- Marelon<sup>®</sup> has passed all the same U.L. testing as bronze. Marelon<sup>®</sup> meets all the requirements under ABYC for domestic use and is I.S.O. Certified for export. Marelon<sup>®</sup> is the only synthetic plumbing system to meet all these standards
- Your customers do not “expect” bronze anymore. Technology has passed bronze by. Your customers expect performance and longevity, ease of maintenance and more enjoyment on the water. You build a composite boat; fiberglass. Your hoses, windshields, dock lines and upholstery are a composite—why not the plumbing?
- **BRONZE v MARELON**
- Bronze prices are tied to the price of copper. Copper has increased over 300% since 2003.
- Bronze is heavy. A 1/1/2” (38.1mm) seacock, thru-hull, tailpipe assembly weighs (on average) 10.2 (4.64kgs) pounds in bronze. Equivalent Marelon<sup>®</sup> assembly—1.7 pounds( 0.77kgs).
- Bronze corrodes. Marelon<sup>®</sup> never will.
- Bronze requires bonding. Remove the labour and expense of all the copper wire needed for bonding and you have further costs savings per boat.
- For a bronze assembly, you have 3 parts; valve, thru-hull and tailpipe or elbow. Marelon<sup>®</sup> assemblies give you all three pieces under one part number—and you don't have to install the tailpipe or elbow. It's already there. This saves you more labour and can reduce inventory.

# **FORESPAR<sup>®</sup>** **MARELON<sup>®</sup>**

**TECH  
TIPS**

## **THE BRONZE AGE**

STEP OUT OF THE BRONZE AGE

DON'T LET THIS HAPPEN TO YOU

INSTALL MARELON FITTINGS



**Forespar<sup>®</sup>**

22322 Gilberto Rancho Santa Margarita, CA. 92688

Ph: 949-858-8820 Fax: 949-858-0505

[www.forespar.com](http://www.forespar.com)

[sales@forespar.com](mailto:sales@forespar.com)

## **Marelon<sup>®</sup> - Marine Grade Plumbing Systems**

- Non-Corrosive
- Non-Conductive
- Fire Resistant
- Impact Resistant (exceeds U.L., ABYC and ISO standards)
- Operating temperature range -40° to 200° F
- U.V. Stabilized
- Light Weight

In the late 1970's we undertook a search for a material that could replace the traditional bronze plumbing components used in boats. The frequency of severe and often catastrophic corrosion and the problem of conductivity in bronze had long been a source of frustration for yacht designers and boat builders. Also, owners had to deal with the risks and cost of the ancient metal in their modern boats. The inherent tendency for bronze to degrade through electrolysis was increasingly becoming a safety issue in the recreational marine industry.

Our development of Marelon<sup>®</sup> plumbing components eliminated the corrosion/electrolysis issues with a superior engineered composite polymer material. It is also less than half the weight of comparable bronze fittings, U.V. stabilized, and will not support combustion - making Marelon<sup>®</sup> a logical choice for today's modern composite hull forms (fiberglass, carbon and Kevlar laminates) in recreational and performance powerboats and sailboats.

Over the last quarter century there have been many thousands of Marelon<sup>®</sup> installations exposed to the extremes of Alaskan waters and Northern European cruising and fishing grounds and the heat and vibration found in engine compartments.

Information supplied:

- Certification summary
- ISO 9093-2 Certification
- ISO and ABYC certificates
- Comparison Chart
- Marelon vx Bronze weights
- Physical properties
- Chemical Resistance
- USCG Imana Labs Fire Test
- Marelon<sup>®</sup> Exceeds American Boat and Yacht Council



## Marelon<sup>®</sup> - Marine Grade Plumbing Systems cont.

### CERTIFICATE SUMMARY

Marelon<sup>®</sup> plumbing components meet many “certifications” however only the Integrated Plumbing Systems (“93” series) carries any of the official certifications as required by law (U.L. label) and ISO Certification. The following may help answer the questions on compliance that routinely come up with builders concerning Marelon<sup>®</sup>.

#### **U.S.C.G.**

Their only interest in plumbing has to do with “vessels for hire” or the charter trade. The Coast Guard does not forbid non-metallic valves and thru-hulls; they simply do not have a standard for them. Marelon<sup>®</sup> valves and thru-hulls have been approved on charter vessels on a “case by case” basis by the local district officer. This year, the Coast Guard office in Washington was supplied with all the U.L. data sheets. While the USCG policy does not affect any of our OEM valves, they can create an obstacle to the boat owner or custom builder trying to get a vessel certified for charter use. We believe they are moving toward an overall approval system based on the U.L. standards. Note: Marelon<sup>®</sup> ball valves did pass the USCG fire test.

#### **A.B.S.**

(American Bureau of Shipping) – We had “type” approval for commercial vessels to 100 feet and non-metallic yachts to 150 feet. The ABS has since pulled out of any “approval” of non-commercial vessels. They no longer have anything to do with recreational boating.

#### **A.B.Y.C.**

(American Boat and Yacht Council) – They have accepted as their own, the U.L. standard for seawalves. We meet and exceed these standards by a wide margin. The ABYC is recognized within our industry as a “standards” writing body. They do not “approve” anything, they only “recommend”. Unfortunately, they are not widely known by the buying public. They should be. The ABYC has done a lot of good for the public, yet they rarely get any recognition. The ABYC & NMMA has now taken over for the U.L.

#### **Marine U.L.**

(Underwriters Laboratories) – The U.L. developed a new set of standards for recreational boats. The ABYC generally parallels these standards. The tests performed to these standards are the same for bronze, stainless or plastic. We exceed these standards with the Marelon<sup>®</sup> Integrated valve systems. Of all the “standards” we have seen worldwide to date, the U.L. standard is the most comprehensive and stringent of them all. The U.L. has giving the recreational marine testing/certification process over to the ABYC and NMMA.

## Marelon<sup>®</sup> - Marine Grade Plumbing Systems cont.

### **CERTIFICATE SUMMARY cont.**

#### **C E (International Marine Certification Institute)**

Based in Belgium, the IMCI is an "International" independent organization that serves the interests of the European and International recreational boating industry. With the establishment of the European Communities Directive for Recreational Craft (94/25/EC) the IMCI provides a certification service to manufacturers who wish to market their boats and other components to the European market. The IMCI has a Board of 24 Directors from 14 countries and was founded by Lars Granholm in 1992. Lars held this position until 2000 when Ulrich Heinemann took his place. In 1996, the IMCI was recognized by the EU (European Commission Notified Body) as "0609" meaning simply that anyone covered under the IMCI standards could display the "CE" mark which allows free and open access to all EU countries.

Since 1996, the only categories of products that are covered or recognized by the CE or IMCI are:

- Ignition protected equipment for inboard and stern-drive engines
- Start-in-gear protection devices for outboard engines
- Steering wheels, steering mechanisms and cable assemblies
- Fuel tanks and fuel hoses
- Prefabricated hatches and port-lights

Note that the boat-builder is ultimately responsible for compliance with the CE directives and obtaining the CE mark.

What this means to Forespar and Marelon<sup>®</sup>...not a thing! Nothing we currently make falls under the CE requirements.

#### **N.M.M.A. Certification**

The only product Forespar makes that meets any of the NMMA's programs is the ML-2 combination bow/deck light under NMMA code #240300 ML-2. As with the CE, the NMMA so far, has not established any "standards" for seacocks or thru-hulls.

#### **I.S.O. International Standards Organization**

This organization is again comprised of an International body to create "standards" for manufactured products. This was started in 1999 (or earlier) and was finally ratified in 2002. As currently written, Marelon<sup>®</sup> ball valves and thru-hulls comply (see the attached sheet for details) with ISO 9093-2 as to physical properties and strength.

All Marelon Integrated Systems valves are ISO Certified per the IMCI directive as of March of 2009. Copy of Certificate can be sent if needed.

Again, the current U.S. Marine U.L. testing standards are the toughest and most comprehensive standard to meet. Marelon<sup>®</sup> is up to the task!

The reason for this information is because there is a lot of misunderstanding of who approves what and what the approvals are for and what it all means. This misunderstanding can keep a Marelon sample on a buyer's desk from going any further in the sales/acceptance process. It may be wise to "Clear the decks" about the "standards" question early on in the presentation of Marelon<sup>®</sup> products.



**INTERNATIONAL MARINE CERTIFICATION INSTITUTE**

International Non-Profit Association

Rue Abbé Cuypers 3 / B-1040 Bruxelles / Belgique / Fon +32 2 741 6836 / Fax +32 2 741 2418  
www.imci.org / info@imci.org

***EC-TYPE EXAMINATION CERTIFICATE***

*We hereby certify that the product below manufactured by*

***Forespar Products Corp.***

*22322 Gilberto - RANCHO SANTA MARGARITA, CA 92688 - UNITED STATES*

***Protection against ignition of surrounding flammable gases***

***12 VDC (MOTORS 931100 & 931200)***

Type  
Certificate number

Motorized valve  
IGPFORE001

***meets the requirements of the Recreational Craft Directive 94/25/EC as amended by 2005/44/EC in accordance with ISO 8846***



**ING. UDO WOLFF P.P.**  
Ulrich Heinemann (Managing Director)  
for EU - Notified Body : 0609

**2014-12-09**

This certificate is valid for product identified as  
**2015 model**



NBN EN45011 accredited organisation - Certificate No 228-PROD





# INTERNATIONAL MARINE CERTIFICATION INSTITUTE

International Non-Profit Association

Rue Abbé Cuypers 3 / B-1040 Bruxelles / Belgique / Fon +32 2 741 6836 / Fax +32 2 741 2418  
www.imci.org / info@imci.org

## CERTIFICATE

*We hereby certify that the product below manufactured by*

***Forespar Products Corp.***

*22522 Gilberto - RANCHO SANTA MARGARITA, CA 92688 - UNITED STATES*

***Model***

***1/2", 3/4", 1", 1-1/4", 1-1/2", 2"***

Type

Integrated Plumbing System

Certificate number

ICFORE001

***meets the requirements of the Recreational Craft Directive 94/25/EC as amended by 2003/44/EC in accordance with ISO 9093-2***



**ING. UDO WOLFFPP™**  
Ulrich Heinemann (Managing Director)

2014-12-09

This certificate is valid for product identified as  
**2015 model**





# FORESPAR MARELON BALL VALVES & THRU-HULL

A.B.Y.C. H-27  
 SEACOCKS, THRU-HULL CONNECTIONS AND DRAIN PLUGS  
 AND  
 ISO/DIS 9093-2 STANDARD  
 SMALL CRAFT - SEACOCKS & THRU-HULL FITTINGS - NON-METALLIC

THE FORESPAR MARELON BALL VALVES AND THRU-HULL FITTINGS MEET AND EXCEED THE ABYC H-27 AND ISO 9093-2 STANDARDS AS PRESENTLY WRITTEN IN ALL RESPECTS.

As to Physical Property Requirements:

	<b>ABYC Standard</b>	ISO Standard	Marelon Properties
Tensile Strength:	75 mPa 10,900 psi	60mPa 9,715psi	121mPa 17,500psi
Flexural Mod.:	3480mPa 505,000psi	2700mPa 391,500psi	4826mPa 700,000psi
Impact Strength:	None	9Kj/m	117j/m

As to Strength Test:                      2224N 500lbs.                      1500N 337lbs.                      2224N 500lbs.

# MARELON COMPARISON CHART

	U.V. Degradation	Corrosion Resistance	Abrasion Resistance	Tensile Strength**	Flexural Modulus***	ABYC * Requirement	U.L. * Requirement	Total Score
<b>MARELON</b>	10	10	10	27,000psi 10	1,300,000mPa 10	10	10	70
<b>NYLON 101</b>	6	10	5	12,000psi 10	410,000mPa 4	0	0	35
<b>ACETAL</b>	5	10	6	10,000psi 5	450000mPa 5	0	0	31
<b>PVC</b>	3	10	2	5015psi 3	434,000mPa 3	0	0	21
<b>POLYPROPYLENE</b>	8	10	7	4150psi 2	75,000mPa 2	0	0	29
<b>BRONZE</b>	10	4	10	35,000psi 10	15,000,000mPa 10	10	10	64
<b>BRASS</b>	10	0	10	45,000psi 10	11,000,00mPa 10	0	0	40
Marelon is a registered trademark of Forespar Products Corp.								
<b>* Minimum physical properties required for approval are:</b>								
	Tensile strength 10,900psi 75mPa							
	Flexural modulus 500,000psi 3480mPa							
<b>** Value by test to ASTM D638 (American Society of Testing &amp; Materials)</b>								
<b>*** Value by test to ASTM D790 (American Society of Testing &amp; Materials)</b>								

## MARELON vs. BRONZE WEIGHTS

		MARELON WEIGHT		BRONZE WEIGHT	
PART # - DESCRIPTION	OUNCES	POUNDS	OUNCES	POUNDS	POUNDS
906024	3/4" THRU HULL WITH NUT	1.6	0.11	8	0.5
906026	1" THRU HULL WITH NUT	2.4	0.15	14	0.875
906028	1-1/4" THRU HULL WITH NUT	3.2	0.2	22	1.375
906030	1-1/2" THRU HULL WITH NUT	4.8	0.3	32	2
906032	2" THRU HULL WITH NUT	7.2	0.45	44	2.75
906059	3/4" SCOOP SCREEN T-HULL	3.2	0.2	15	0.937
906060	1-1/4" SCOOP SCREEN T-HULL	5.6	0.35	20	1.25
931143	3/4" SEA VALVE W/T-HULL & BARB	10.4	0.65	48	3.01
931144	1" SEA VALVE W/T-HULL & BARB	17.6	1.1	72	4.5
931145	1-1/4" SEA VALVE W/T-HULL & BARB	17.6	1.1	100.5	6.281
931146	1-1/2" SEA VALVE W/T-HULL & BARB	27.2	1.7	164	10.2
931148	2" SEA VALVE W/T-HULL & BARB	28	1.75	209	13.06

**SAVE FUEL!    GO FASTER!    GO FARTHER!**

**MARELON IS THE WEIGHT SAVINGS CHAMPION!**

# Marelon<sup>®</sup> Physical Properties

<u>Property</u>	<u>ASTM Method</u>	<u>Units</u>	<u>Value</u> <u>50% RH</u>
Tensile Strength	D-638	psi	8,700
Elongation	D-638	%	14.0
Izod Impact Strength	D-256	ft lb/in	4.0
Unnotched			20.0
Flexural Modulus	D-790	psi	320,000
Combustibility	UL-94		94 HB
Specific Gravity	D-792		1.19
Glass Content		%	14

## ISOCHRONOUS STRESS VS. STRAIN MARELON<sup>®</sup> 23°C (73°F), 50% RH

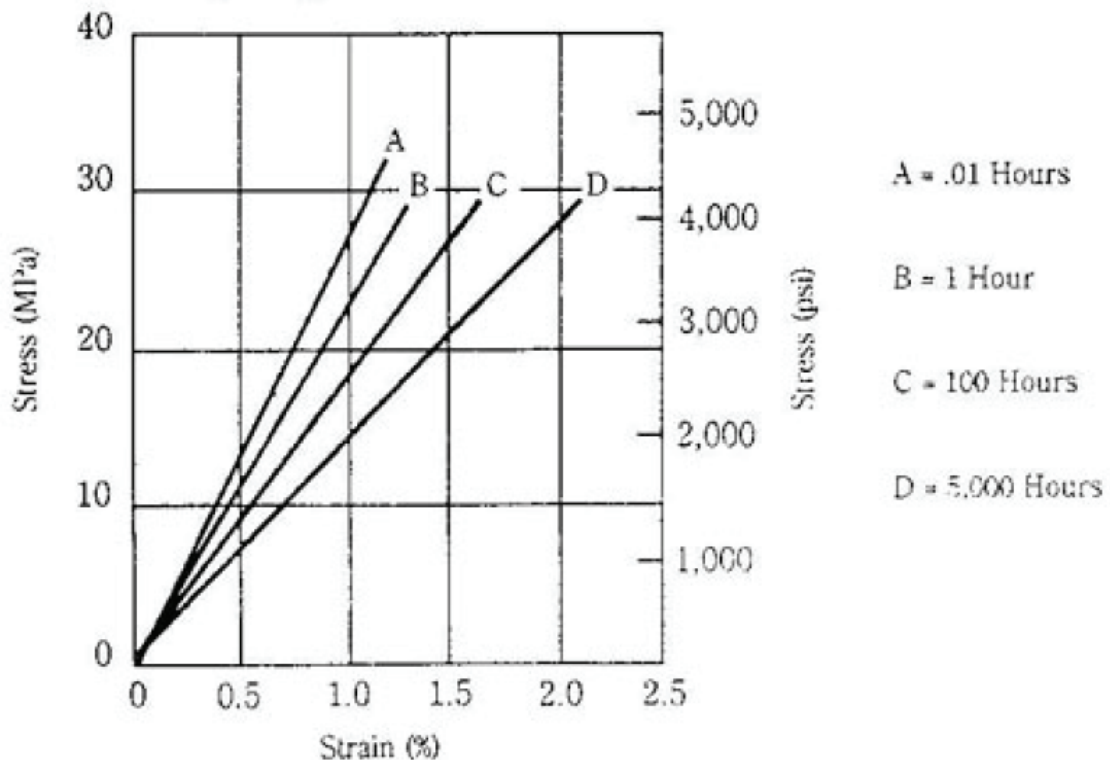

**CREEP VS. TEMPERATURE AT 10,000 HOURS, GLASS-REINFORCED MARELON<sup>®</sup>**

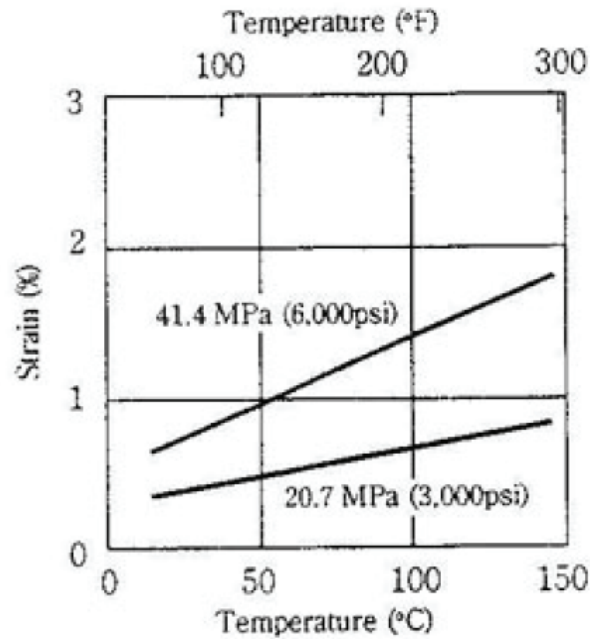

**IZOD IMPACT RESISTANCE VS. TEMPERATURE AND HUMIDITY**

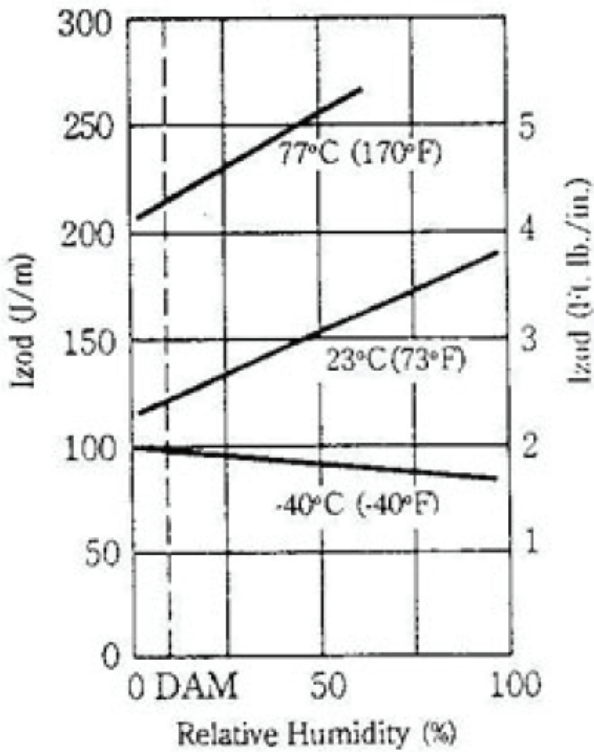

**IZOD IMPACT RESISTANCE VS. RELATIVE HUMIDITY, 23° (73°F) 305MM (1/8") BAR NOTCHED.**

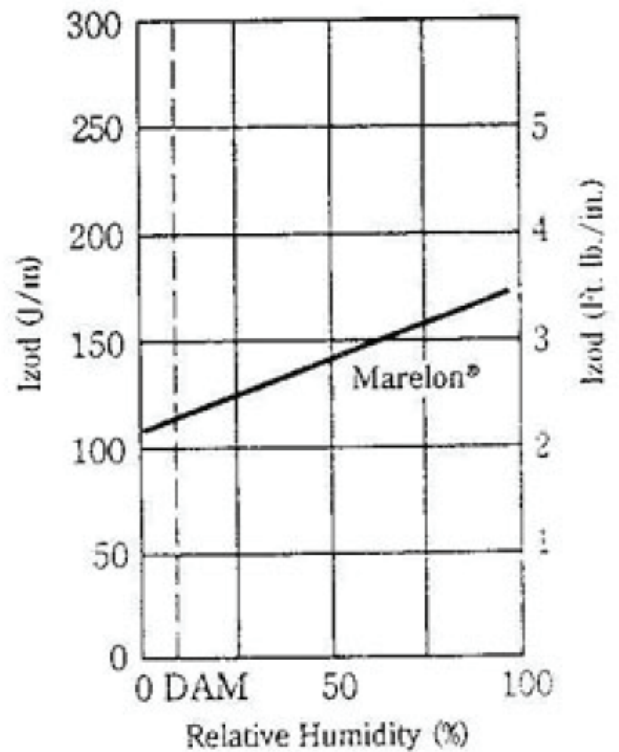

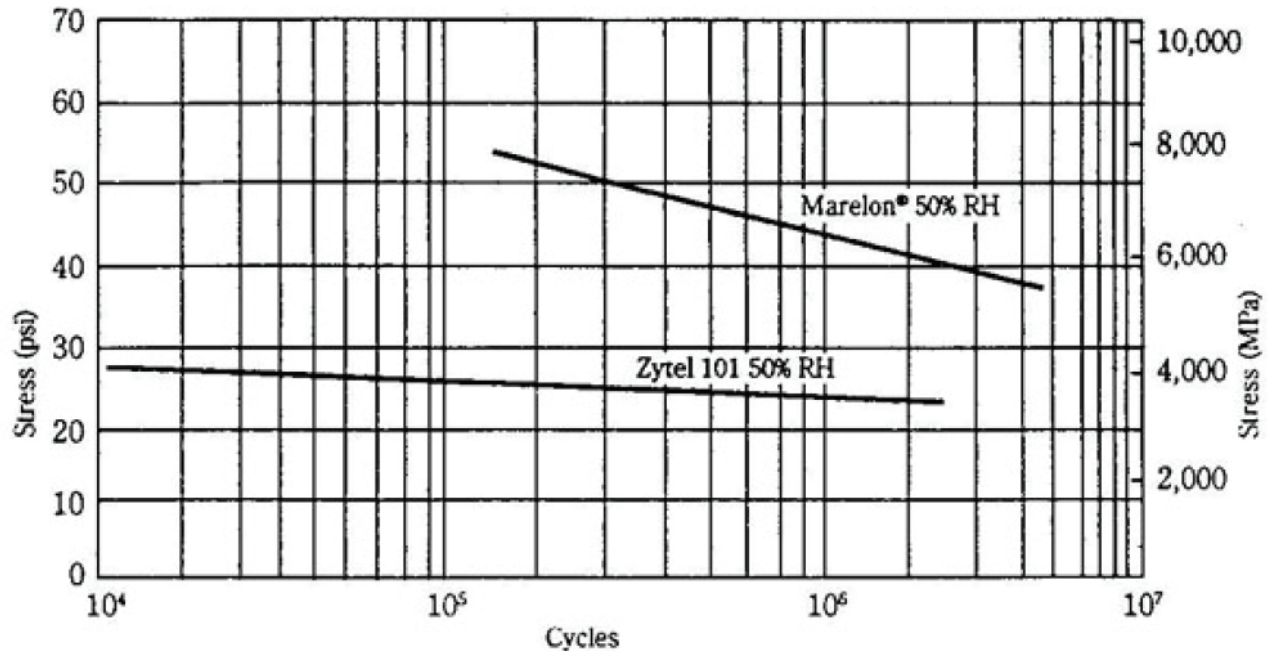
**FATIGUE RESISTANCE, TENSION-COMPRESSION 1800 CYCLES/MIN,  
MARELON<sup>®</sup> VS. ZYTEL 101****Marelon<sup>®</sup> is:**

- Non Corrosive
- Non Conductive
- Fire Resistant
- High Impact Resistant
- Temp. -40°F to 176°F  
-40°C to +80°C
- U.V. Resistant

# CHEMICAL RESISTANCE CHART

**NOTE!** THIS CHART SHOULD BE USED AS A GUIDE ONLY. IT IS RECOMMENDED THAT PRACTICAL TESTS BE CARRIED OUT ON FITTINGS INTENDED FOR USE WITH SPECIFIC CHEMICALS. ADDITIONAL INFORMATION MAY ALSO BE OBTAINED FROM OUR OFFICES.

		UNACCEPTABLE	POOR	FAIR	GOOD	EXCELLENT
Aliphatic Solvents	1	_____				
	2	_____				
	3	_____				
	4	_____				
Aromatic Solvents	1	_____				
	2	_____				
	3	_____				
	4	_____				
Chlorinated solvents	1	_____				
	2	_____				
	3	_____				
	4	_____				
Esters & Ketones	1	_____				
	2	_____				
	3	_____				
	4	_____				
Halogens	1	_____				
	2	_____				
	3	_____				
	4	_____				
Strong Acids	1	_____				
	2	_____				
	3	_____				
	4	_____				
Strong Bases	1	_____				
	2	_____				
	3	_____				
	4	_____				
Strong Oxidants	1	_____				
	2	_____				
	3	_____				
	4	_____				
Weak Bases And Salts	1	_____				
	2	_____				
	3	_____				
	4	_____				

CHEMICAL RESISTANCE CHART

- 1—NYLON
- 2—ACETAL
- 3—POLYPROPYLENE
- 4—KYNAR<sup>®</sup>

\*TRADEMARK  
 PENNWALT CORP.



**CERTIFICATION TEST REPORT**

P.O. Box 560933 • Rockledge • FL 32956-0933  
407-632-2008 • FAX 407-690-3360

[ Fores Mfg., Corp.  
22322 Gilberto  
Rancho Santa Margarita, CA 92688 ]

REPORT NO. 12490-1  
IMANNA JOB NO. 12490  
CUSTOMER P.O. NO. Verbal

MANUFACTURER Forespar®

CONTRACT N/A

DATE July 27, 1993

8  
PAGE REPORT

CERTIFICATION TEST REPORT  
12490-1 OF  
USCG FIRE TEST ON  
¾" MANUAL SHUT-OFF FUEL VALVE  
FOR

FORES MANUFACTURING

1. SPECIMEN

The test specimen is a ¾" manually operated fuel supply shut-off valve. The valve is made of Marelon® synthetic material. The valve has a hose barb for ¾" hose on each end.

2. MODEL NUMBER

Forespar®, R C Marine ¾" , Marelon®, Part No. 934143.

3. REQUIREMENTS

The requirements of this effort are to perform a 2¼ minute fire test in accordance with the USCG requirements utilizing the Fire Test Chamber method. The test is to determine the acceptability of the unit for use in a permanently installed gasoline fuel system in a marine application.

4. PROCEDURES

The procedure used in performing this test program is the USCG Fuel Systems Standard Test Procedure, specifically Lab Examination No. 14, Titled Fire Test of Fuel System Components.

The procedure utilizes a Fire Test Chamber, and requires that the temperature within 1" of the component hit 1200°F at some point in time within the 2¼ minute fire.

STATE OF FLORIDA  
COUNTY OF BREVARD

ROBERT L. WHITE

, being duly sworn,  
deposes and says: The information contained in this report is the result of complete and carefully conducted tests and is to the best of his knowledge true and correct in all respects.

SUBSCRIBED and sworn to before me this 27 day of July, 19 93

Dana H. Higgins  
Notary Public in and for the County of Brevard, State of Florida.

My Commission expires May 3 1997

Imanna shall have no liability for damages of any kind to person or property, including special or consequential damages, resulting from Imanna's providing the services covered by this report.

IMANNA LABORATORY, INC.

TEST BY

ROBERT L. WHITE

PROJ. ENGINEER



PAGE NO. 2

TEST REPORT NO. 12490-1

**5. TESTING SEQUENCE**

- A. Receiving Inspection
- B. Fire Test
- C. Post Fire Inspection

**6. RESULTS**

The results of the tests indicate that the component does meet the requirements of the USCG regulation for fire resistance in its current design configuration. The valve showed no signs of fuel leakage following the fire test, when the unit was leak tested with a 36" head pressure of gasoline.

**6.1 RECEIVING INSPECTION**

The units which were received appeared to be complete in all respects. Each valve was fitted with a ¼" hose barb fitting on the inlet and the outlet. The valves were 90° ball valves, with the flow direction marked on the handle. The end fittings were installed using Stainless Steel through-bolts with Lock nuts.

**6.2 FIRE TEST**

The unit was placed in a Fire test chamber and tested in accordance with the USCG Procedure. During the test period, the temperature increased to a maximum of 1275°F, but remained at approximately 850°F to 980°F for most of the time.

**6.3 POST FIRE INSPECTION**

The post fire inspection and leak check indicated that no leak was present on the test article.

**7. OBSERVATIONS AND COMMENTS**

The results presented herein apply only to the test specimen, as prepared and as tested. Test equipment used in the performance of this test was calibrated to standards traceable to the N.I.S.T.

## THRU-HULL/SEAVALVE INSTRUCTIONS

**Integrated Valve Systems** This marine seavalue is made of MARELON<sup>®</sup>, a glass reinforced nylon composite. It exceeds standards for use set by the U.L. (Underwriters Laboratory) and the American Boat and Yacht Council (A.B.Y.C.). It is a complete system including thru-hull fitting, valve body, and hose connector.

**HULL OPENINGS:** Prepare a clean round hole in the desired location and of the appropriate diameter for the chosen thru-hull fitting per the requirements below. For flush head thru-hull fittings only, make an external 45 deg. chamfer 1/4" deep. If the recommended backing block is used, a uniform hole diameter must extend through the backing block.

- 1/2" and 3/4" Thru-hull/seavalves – 1-1/8" hole
- 1" and 1-1/4" Thru-hull/seavalves – 1-1/2" hole
- 1-1/2" and 2" Thru-hull/seavalves – 2-1/8" hole

**BACKING BLOCKS:** A backing block or an equivalent structure molded integrally into the resin/glass hull lay-up is required for installations on all non-flat hull surfaces. This is also recommended procedure for flat surfaces as well. For wood backing blocks, white oak is a commonly used wood. There may be other suitable materials as well.

**THRU-HULL FITTING LENGTH:** The thru-hull fitting, when fully installed, should project beyond the internal hull/backing block surface no less than 1/2" and no more than 1-1/4". Engagement of five (5) full threads will generate the full loading strength of the thru-hull/seavalue assembly, which is well in excess of the 500 pounds, required by the U.L. and A.B.Y.C. standards.

**BEDDING:** The thru-hull fitting's external flange should be properly bedded when the fitting is inserted into the hull. The exposed male threads protruding from the inside of the hull should be applied with Bedding material as well. The surface of the female threaded round king-nut portion of the valve, which interfaces with the internal hull surface, may well be bedded also, but it is not an absolute requirement and the loading strength will not be impaired if it is not done. Bedding compounds such as 3M's #5200, Sikaflex or Boatlife are to be recommended as well as others that are equally suitable.

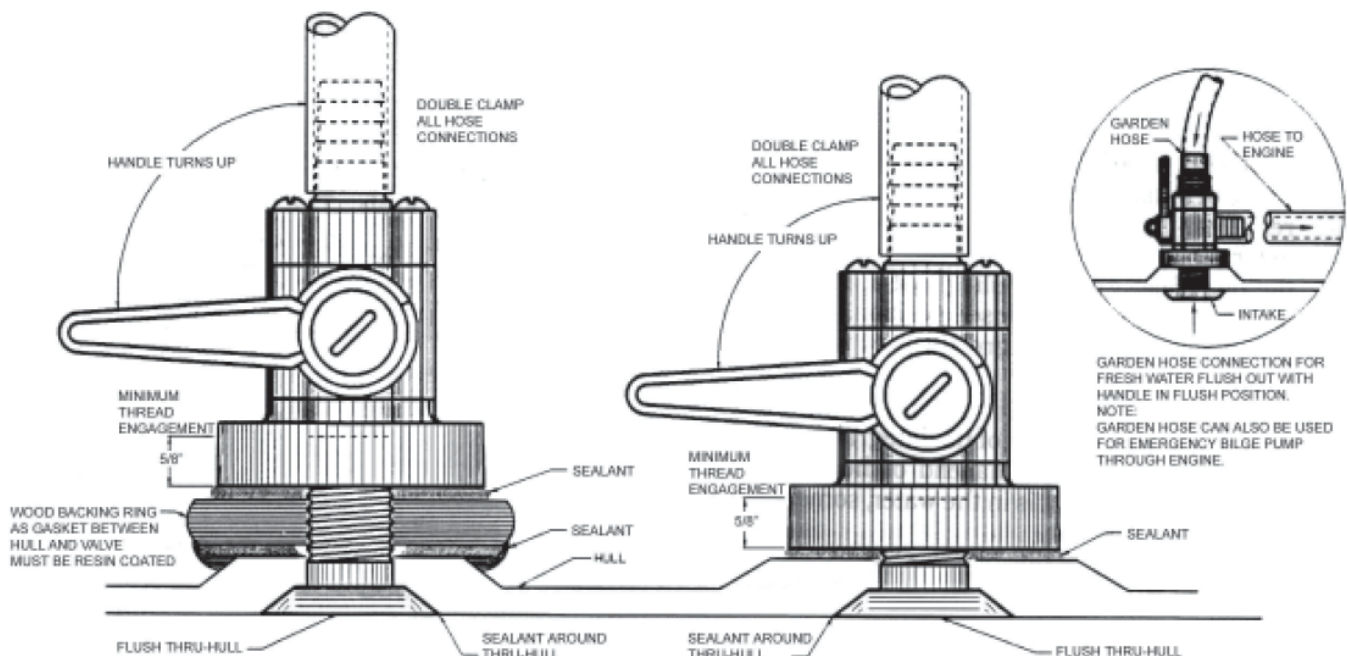

## Thru-hull/Seavalue Instructions cont.

**“93” SERIES THREAD FORM:** The thread form used on these thru-hull fittings and king-nuts is a non-tapered buttress type of thread design. This thread form has a higher load carrying capacity, particularly for polymeric materials. **Warning, a standard pipe threaded thru-hull fitting will not fit with the king-nut on these valves.** For a standard pipe threaded thru-hull fitting, use our valves that have standard female pipe thread outlets instead of a king-nut base. A buttress thread design with the same amount of clearance as for a conventional pipe thread will give the impression of greater looseness. However, when the joint is taken up tight, there is a greater area of surface between threads with the buttress thread form. **As with any threaded pipe assembly, Teflon<sup>®</sup> tape should be applied to the thru-hull threads for a watertight connection.**

**KING-NUT INSTALLATION:** The fully assembled valve is threaded onto the bedding coated thru-hull fitting and tightened down by turning either the thru-hull fitting or the king-nut/valve assembly. A firm, hand-tight mount is sufficient, but if preferred, the nut can be torqued to a maximum of 12foot-pounds. If it is desired to additionally fasten the king-nut to the backing block with screws, there is provision for such, but it is completely unnecessary. On the backside of the king-nut there are four (4) blind ¼” holes. These may be drilled through to the front side before installation to allow for round-headed screw fasteners.

**VALVE CONNECTIONS:** It is recommended that all hose barb connections be made using two(2) all stainless steel hose clamps. For ½” and ¾” barbs, use 3/8” wide hose clamps. For 1” and larger connections, use ½” wide hose clamps. If the valve configuration being used has a female pipe threaded inlet, use care in the installation of the pipe nipple or elbow. Use a Teflon<sup>®</sup> pipe sealant. Be sure you are not cross threading by improper alignment and do not torque more than 12 foot-pounds.

**MAINTENANCE: FORESPAR<sup>®</sup> MARELON<sup>®</sup> Thru-hull/seacocks are corrosion free and provide great peace of mind in that regard. They are relatively maintenance free. Generally, lubrication is not required. What is required is to open and close them on a regular basis(4 times a year minimum). The frequency this is required is determined by two (2) things, whether the valves are routinely kept open or closed, and the rate of sea growth (weed and barnacles) in your area. If the rate of fouling is high and the valves are not actuated regularly, this build up of growth can cause any valve to turn hard or not at all. If the valve becomes stiff due to lack of use and sea growth build-up, it must be cleaned. The restriction of flow into the valve may cause harm to the machinery it serves and the valve may seize if not maintained.**

**DO NOT DISASSEMBLE VALVE OR LOOSEN BOLTS EXCEPT INEXTREME EMERGENCIES.** All valves are factory pressure tested before shipping. Any adjustments to the bolts will void this testing and may void warranties.

All MARELON<sup>®</sup> integrated valves have a removable plug in the handle (white cap with loop). This plug is made to fit into the external thru-hull (non-screened style only). In an emergency, this plug can be placed in the thru-hull (water pressure will keep it in) and the valve disassembled while the boat is in the water. Someone must get wet, but the boat does not need to be hauled for valve repairs. By tying a lanyard to the cap, you need only get wet once

## Thru-hull/Seavalue Instructions cont.

DIMENSION	12.7 & 19	25.4 & 31.8	38 & 50.8
MAJOR DIA.	44	56	71
MINOR DIA.	32.5	43.2	55.4
OUTSIDE DIA.	28	40.6	53.3
INSIDE DIA.	15.8	26.7	41.7
KING NUT DIA.	79.5	95.3	106.9

DIMENSION	1" & 1-1/4"	1-1/2" & 2"
MAJOR DIA.	2.20	2.79
MINOR DIA.	1.70	2.18
OUTSIDE DIA.	1.6	2.1
INSIDE DIA.	1.05	1.64
KING NUT DIA.	3.75	4.21

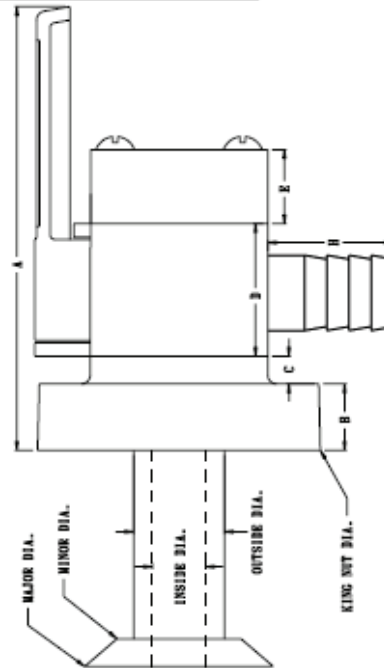
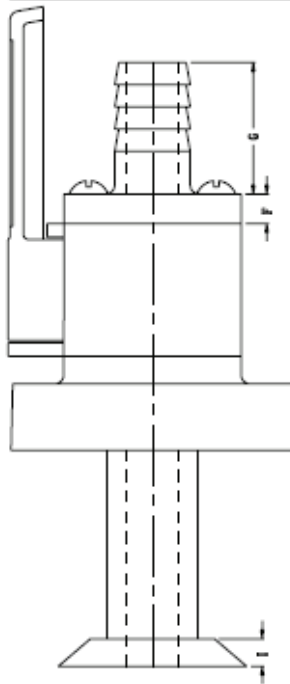

ALL DIMENSIONS IN MILLIMETERS

ALL DIMENSIONS IN INCHES

## **Thru-hull/Seavalue Instructions cont.**

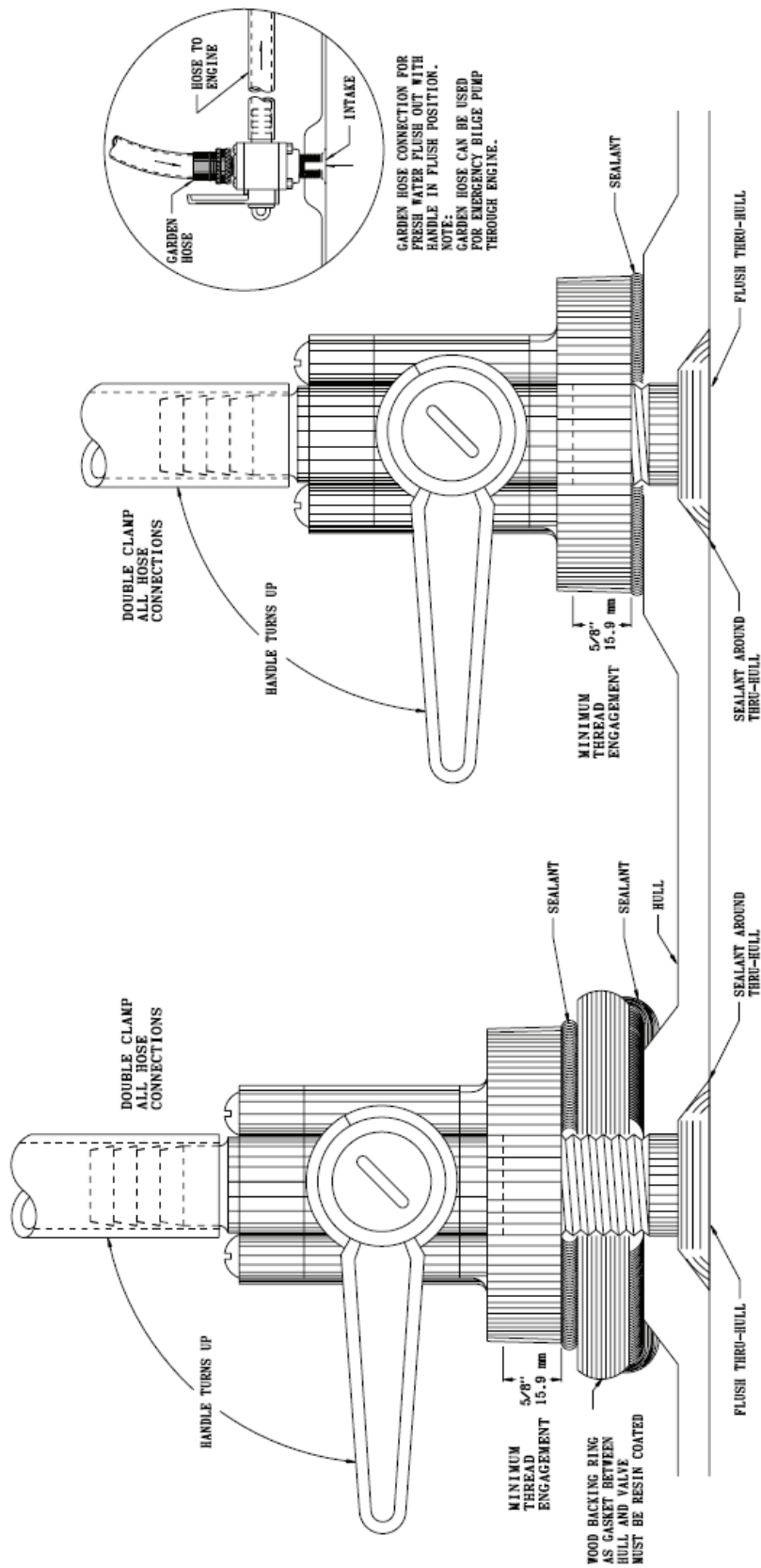

**Forespar<sup>®</sup>**

22322 Gilberto Rancho Santa Margarita, CA. 92688  
Ph: 949-858-8820 Fax: 949-858-0505

[www.forespar.com](http://www.forespar.com)    [sales@forespar.com](mailto:sales@forespar.com)

## What is Marelon

Marelon<sup>®</sup> is a proprietary formulation of polymer composite compounds using engineered resins and additives to produce a superior marine-grade product.

Benefits to builders include:

- Light weight, yet extremely strong injection-molded parts
- Complete freedom from any corrosion
- Complete freedom from electrolysis or reaction to any metals
- Outstanding operating temperature range (-40deg. to +176deg. F.)
- Uses in deck hardware (cleats, chocks) and marine plumbing
- Outstanding U.V. resistance and color fix
- Marelon<sup>®</sup> valves offer an unprecedented variety of designs
- Marine U.L. approved and A.B.Y.C. accepted , ISO Certified
- Long term reliability

Benefits to the Boat Owner include:

- No bonding (electrical) required
- Configurations to fit tight machinery spaces
- Minimal maintenance requirements
- Ease of installation with standard tools
- Accepts adhesives and coatings (bottom paints) easily
- Can be used on aluminum, steel, wood or FRP hull forms
- Marine U.L. approved and A.B.Y.C. recognized , ISO Certified
- Excellent chemical resistance to harsh bilge cleaners
- Can be used with or on any metal fittings
- Long term reliability

## FLOWTECH VALVE INSTALLATION

# 905106  
# 905109

When properly installed, the design characteristic of these valves, in their closed position, provides a smooth unbroken surface on the outside of the hull. There will be no protrusions or cavities to disturb the even flow of water along the hull surface.

The following installation method is one used by quality builders familiar with these types of valves.

Provide a 1-7/8" (48mm) hole in the hull with a reasonably flat internal surface where the inner hull will interface with the valve's flange. Be sure the valve is in the closed and locked position and the surfaces to be bonded are clean and free of any contaminate that may have gotten on the valve. Wipe bonding surfaces with acetone.

Prepare a bedding compound of Cabacill and resin, polyester, vinylester or epoxy. Spread this material on all hull and valve surfaces that will be interfacing. Be sure to work the compound well into the inside surfaces of the hole in the hull and into the ribs of the valve. Insert the valve into the hole and make sure that at least a small amount of the compound squeezes out from under the flange of the valve body. Do not press the valve against the hull hard enough to flex the flange as this could result in voids being created when the flange is allowed to spring back to its normal form.

Follow this with four or five laminations of 17oz. "E-Glass" and resin of the type used for the hull lay-up. The Polyester, vinylester and epoxy resins bond very well to the Marelon<sup>®</sup> valve material. Make each successive layer of glass larger in diameter until the final lamination extends a minimum of 3" beyond the edge of the valve flange.

When all resins are cured, the portion of the valve that extends beyond the outer hull surface can be disked off to a smooth flush surface. The valve must be in the fully closed and locked position when doing this final finishing procedure. A minimum of 5/8" bury (hull thickness) is required on both the #905106 and #905109 Flowtech valves for proper installation. This bury can be in the backing block inside the hull.

Repair Kit available # 905107



# MARELON®

## “FLOWTECH VALVE INSTALLATION” cont.

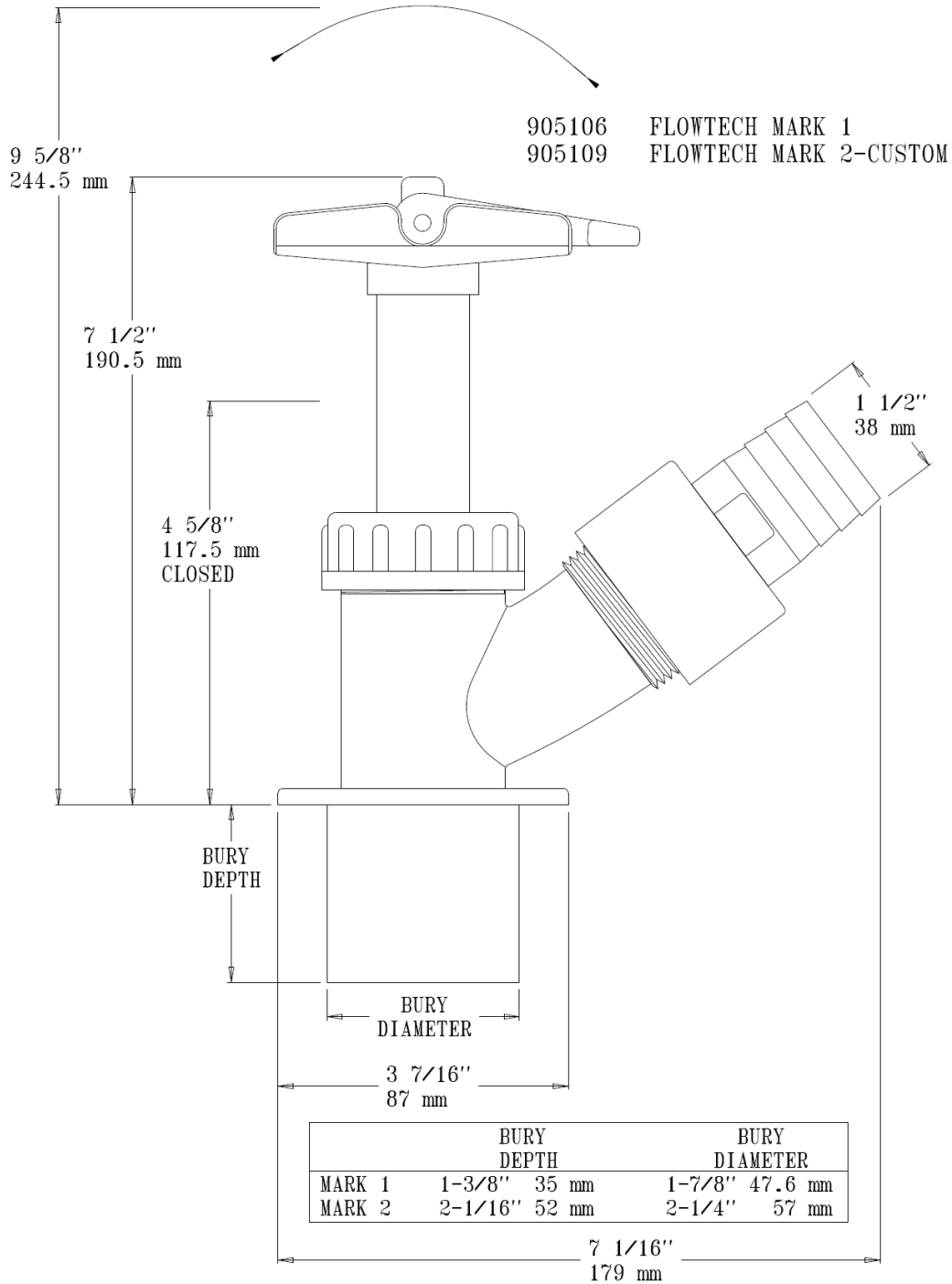



## Plastic Prejudice

*Not just any plastic can withstand the rigors of constant immersion in salt water, regular contact with harsh chemicals, vibration and UV attack. Do you know what you're buying?*

By Patricia Kearns

The following is quoted from a key scene occurring early in the film, "The Graduate."

Mr. McGuire (to Benjamin): "I want to say one word to you. Just one word."

Benjamin: "Yes, sir."

Mr. McGuire: "Are you listening?"

Benjamin: "Yes, I am."

Mr. McGuire: "Plastics."

With hindsight, we see just how prophetic these words were in 1967. Facsimiles of almost anything that can be fabricated of wood or metal and even cotton and wool, can now be made from plastic in some form. That evolution has brought plastics into boats, marine accessories, equipment, attire and even charts.

It's taken generations of engineering wizardry, a great deal of it fueled by the NASA space exploration program, to bring the generic plastic to its current state of utility. Along the way, we've seen considerable resistance to the use of plastic in boats, where previously only wood or metal would do. The fact is that the plastic materials of today are rocket science and the formulas and physics of plastic have been tested and proven in outer space applications. This doesn't mean that all things plastic are suitable for space age applications. With plastics, performance is directly proportional to cost. Let's find out why.

### Plastic's Status

Plastic prejudice is not hard to understand. Early plastic products often were cheap and flimsy and there was a prevailing perception that if a product was plastic and made elsewhere, it

was junk. Fortunately, this synthetic material was being studied in earnest in the chemistry lab by physicists for its strength properties and observed in practical applications. Promoters of the future of plastic, manufacturers like Cargill, Corning, Dow and Dupont were persistent and optimistic. Now, there is a plastic with the performance characteristics to meet almost any need in virtually every product. Stuff is made of plastic, wrapped in plastic, paid for with plastic, carried home in plastic and, eventually, dumped into a plastic recycling bin to begin life again as something plastic.

Plastic, in all its forms, starts its life as a derivative of another product of critical means in our lives. Synthetic generic plastic begins with fossil fuel. From there, initially as a resin, the molecular structure can be chemically and dynamically engineered to be everything it can be and even the extent of that is still unknown. Plastic developers can impart the desired properties of hardness, durability, elasticity and resistance to heat, cold and acids, along with any color or shape and combinations of all or a few of these performance and appearance characteristics into virtually any plastic product.

Enter fiber-reinforced plastic (a.k.a. fiberglass, fiberglass-reinforced resin or glass-reinforced plastic) and you have the fiberglass boat. Actually, what we really mean is the mostly fiberglass boat because even the "fiberglass" is often further engineered and into a structure that comes to be known as a laminate and that laminate can embed wood or other materials, even other kinds of plastic, to further reinforce the structure. That kind of plastic is what legendary yacht

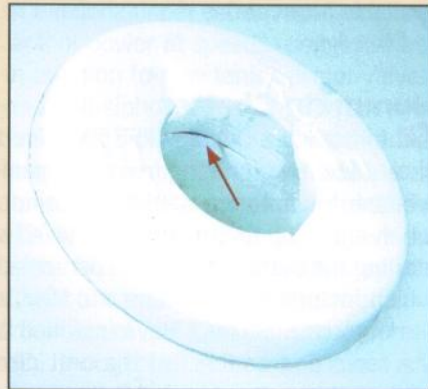

*The perfect example of a failed plastic thru-hull fitting (note the crack). It will eventually break off at the inside nut causing the bilge pump discharge to flow back into the bilge.*

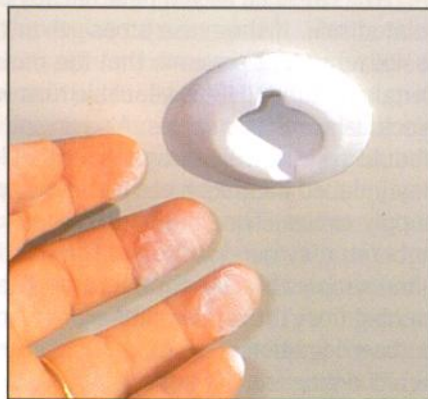

*Chalky residue indicates UV attack and breakdown of inferior plastic thru-hull.*

designer Nathaniel Herreshoff referred to as "frozen snot," an ultimate among the pejorative descriptions of plastic.

A dictionary of plastics includes, to name a few examples: acrylic, Bakelite, Cellophane, Celluloid, Lucite, melamine, phenolic, Plexiglas, polyacrylic, polycarbonate, polyethylene, polyolefin, polypropylene, polystyrene, polyurethane, resin and vinyl. As boaters, we're familiar with many of these names, as we've seen them as ingredients on labels of products we've used for a long time. Where plastic has met with prejudice in its applications in boats has been when the material or the performance specification for a material has been misunderstood. The most common areas where plastic has been accepted without reservation are adhesives and other maintenance compounds, carpet and upholstery, cabin and deck liners, electronics, flotation, furniture, hatches and windshields, molded interior modules, et al. The areas that bring trepidation and



*Don't disregard the obvious warning label attached to this plastic fitting.*

irrational fear to boaters have been plastic thru-hull fittings and valves, pipe and pipe fittings (including PVC), fuel tanks, filters and fittings, propellers and other components of a boat that, when they fail, they fail big-time and failures can be catastrophic.

### Simply Marine

In much the same way as metals are alloyed (metals mixed with metals in prescribed proportions) to meet the needs for strength, corrosion resistance, hardness, malleability, etc., plastics can be formulated and engineered for special applications. Using the right plastic is the key to success in fabrication and application.

Let's blow plastic's bad rap as a material for thru-hull fittings right now. Common plastics found in hardware and building supply outlets are not intended for use as boat fittings. The dynamic and atmospheric exposures inherent in boats are entirely different and more demanding than those of a building on land. Requirements for boats are found in ABYC standard H-27. It's a common misconception that plastic thru-hull fittings are not permitted below the waterline. Wrong! If the material and design meets H-27, which reads as follows, it's acceptable. "All plastic fittings shall meet the following minimum physical properties: a minimum tensile strength greater than 10,900 psi (75 mPa), when tested to ASTM D638; and a flexural modulus greater than 500,000 psi (3,480 mPa), when tested to ASTM D790; and shall contain ultraviolet light inhibitors." This requirement applies only to dry, molded samples of a natural color. Colorants or other additives can change the physical property values. All fittings that meet the requirements may be marked "ABYC H-27."

### Safeguards

The trick is to know if the material does, indeed, comply. Marelon is a brand name held by Forespar for a plastic that is a formulation of glass-reinforced Dupont zytel. Marelon fittings meet the materials' requirement of ABYC H-27. Other than Marelon fittings, any plastic that can be verified (tested by an independent laboratory such as UL) as complying with the H-27 standard can be used above and below the waterline. Look for the marking or check with the manufacturer. Just because something is sold in a chandlery does not make it good for you. Don't accept assurances of store staff that anything else complies. If you chose to accept such an attestation, get the clerk to put his/her opinion in writing and keep it for the day that fitting fails. Then you'll know where to point your legal eagle's finger.

As for other areas of plumbing systems, there are no restrictions on the use of plastic. There are cautions when using PVC. Sections of flexible piping (hose) should be integrated with PVC to mitigate the effects of vibration. One exception to this generality is engine exhaust piping. ABYC P-1 has a table of materials approved for use in exhaust piping. If, at some point, a plastic can be certified to comply with P-1's material standard, you could use it.

Another area of plastic hysteria is gasoline and diesel fuel systems. Once again, we turn to language in the ABYC standards. In this case, ABYC H-24 (Gasoline Fuel Systems) and H-33 (Diesel Fuel Systems) are the references of biblical proportions. H-24 reads as follows: "All individual components of the fuel system, as installed in the boat, shall be capable of withstanding a 2-1/2 minute exposure to free burning fuel (N-Heptane) without leakage as required by Title 33 CFR, Section 183590, and as required for individual components in H-24." There are additional requirements for portable and permanently installed plastic fuel tanks but, if a tank has been tested for compliance and is certified to comply, that plastic is suitable for use on a boat. Beware, though, of willy-nilly selections of plastic lines, fittings, connectors and tanks. You must be extra careful to ensure that what you buy or accept as suitable plastic is, in fact, in compliance with the standard.

### Plastic's Worth

Is price the principle dictator of quality? A Marelon thru-hull fitting likely cost twice as much as its common plastic counterpart. The best sanitation hose is worth every inch of its extra cost since the effort required to replace hose that carries sewage is the same, whether you use cheap or expensive hose. Just as important to quality issues is the relationship between a plastic component's chemical formulation and its intended use. "Good" might be okay for plastic fittings connecting a potable water system but "best" (i.e. Marelon or its equivalent) is the only choice for non-metal thru-hull fittings, valves, holding tanks, cleats and other critical components where a failure could cost heavily in repairs to your boat or jeopardize life and limb.

The sticking point for most of us is how to know what you need to know. Non-compliance by new boat manufacturers is relatively rare. The problems occur when you or your mechanic are replacing original equipment. What is readily available at auto parts suppliers is not likely to have been tested to the marine standard and is not "just as good." One way to cover yourself when giving a work order to a professional is to specify complying parts for the job and require that the compliance proof is available to you. Another way to reach the comfort level is to deal with ABYC certified technicians who are committed to doing their work by the book. Otherwise, it's up to you to make sure you are getting the real McCoy. It's worth the effort. The consequences could be hazardous to your boating health and welfare.

About the author: Patricia Kearns is DIY's technical editor.



## MareLube™ REACH



#770049 30cc Syringe with applicator tube (UPC #028026199171-7)

Made from long-lasting PTFE-based lubricants, MareLube™ REACH is formulated using advanced lubrication technology designed to keep marine valve seals and balls working smoothly. It also works well on hinges, tracks, seat slides and almost anything else that moves. The 30cc Syringe pack comes with an applicator tube specifically for use on valves. Makes reaching the ball easy – even when an elbow is attached!

- Specifically designed for superior lubrication of Marelon® valves or other marine valves
- MareLube™ is a clear, non-staining and nontoxic lube that works equally well in fresh or salt water
- Keeps moving parts moving and has many lubrication uses around the boat, house or shop
  - Effectively fights corrosion, non-conductive
  - Contains no petroleum
  - ISO 9001 Certified
- For more information go to [www.forespar.com/marelube](http://www.forespar.com/marelube)

**Forespar®**

22322 Gilberto

Rancho Santa Margarita, CA 92688 USA

Ph: 949-858-8820 Fax: 949-858-0505

[www.forespar.com](http://www.forespar.com) [sales@forespar.com](mailto:sales@forespar.com)



# **DeckHardware**

For more information on the Forespar® Marelon® range of product contact our office on 02 99059400 or go to our website [www.deckhardware.com.au](http://www.deckhardware.com.au).

You will find more Tech tips and catalogues to download or ask us for our Free Disc with all of this information available for you to go through in your own time.

# **FORESPAR®**

---

# **MARELON®**

PT & RG Yeomans P/L T/As DeckHardware Australasia  
Factory 5, 122-126 Old Pittwater Rd, Brookvale NSW 2100  
Ph 61 (0)2 9905 9400 Fax 61 (0)2 9905 9455  
Email: [info@deckhardware.com.au](mailto:info@deckhardware.com.au) Website: [www.deckhardware.com.au](http://www.deckhardware.com.au)  
[www.facebook.com/deckhardware](http://www.facebook.com/deckhardware) [www.twitter.com/deckhardware](http://www.twitter.com/deckhardware)

